

Thermo Scientific TRACE GC Ultra



Performances Beyond Limits



Innovative advances for unprecedented reliability and productivity



Ultra in system automation and usability



Flexibility for wide range of samples



Powerful options for ultra speed and throughput

“Beyond” conventional Gas Chromatography

Introducing the “Ultra” concept

Ultra in System Usability

The ability to easily provide the most appropriate solution in a highly reliable manner can make the difference between “just another” GC and the “right” GC.

In addition to featuring a complete list of highly technological injectors, the Thermo Scientific TRACE GC Ultra can provide any solution in the simplest and most straightforward way. Powerful synergy with specific accessories can drastically transform the system, add value and improve performance.

Unequaled stability results from the combination of a highly reproducible, fast oven capability (120 °C/min) and state of the art pneumatics.

Injectors: Accuracy and precision granted by more than forty years of recognized innovations in inlet technology!

Accessories: Small devices or full-size options make TRACE GC Ultra™ your evolving platform.

Pneumatics: Unique characteristics add accuracy and precision besides flexibility and ease of use to your daily work!

Ultra in Reliability

Play safe with the highest level of toughness and robustness of the hardware for demanding daily operations. Experiment with the unique features of re-designed pneumatic modules for highly accurate and repeatable analytical results.

Ultra in Speed

Imagine the ability to squeeze your analyses down to 1-2 minutes. Imagine the ability to reduce your analytical cycle by up to a factor of 35.

Now stop imagining – it’s true! No more speed limits with the new Direct Column Heating Technology. Just equip your standard SSL inlet and FID detector with the UltraFast column module and... experience the adrenaline of speed on a standard instrument.

The Thermo Scientific TRACE GC Ultra responds to the needs of modern laboratories for higher productivity and increased sensitivity.

The “Ultra” platform combines the reliability of the TRACE GC with further extended overall system usability, performance, and automation.

Go faster than any speed limit and beyond any sensitivity boundary with the highly innovative content of the new UltraFast and Large Volume Splitless techniques.

Go through a 3D peaks experience thanks to the utmost separation capability of the innovative multidimensional GCxGC technology.

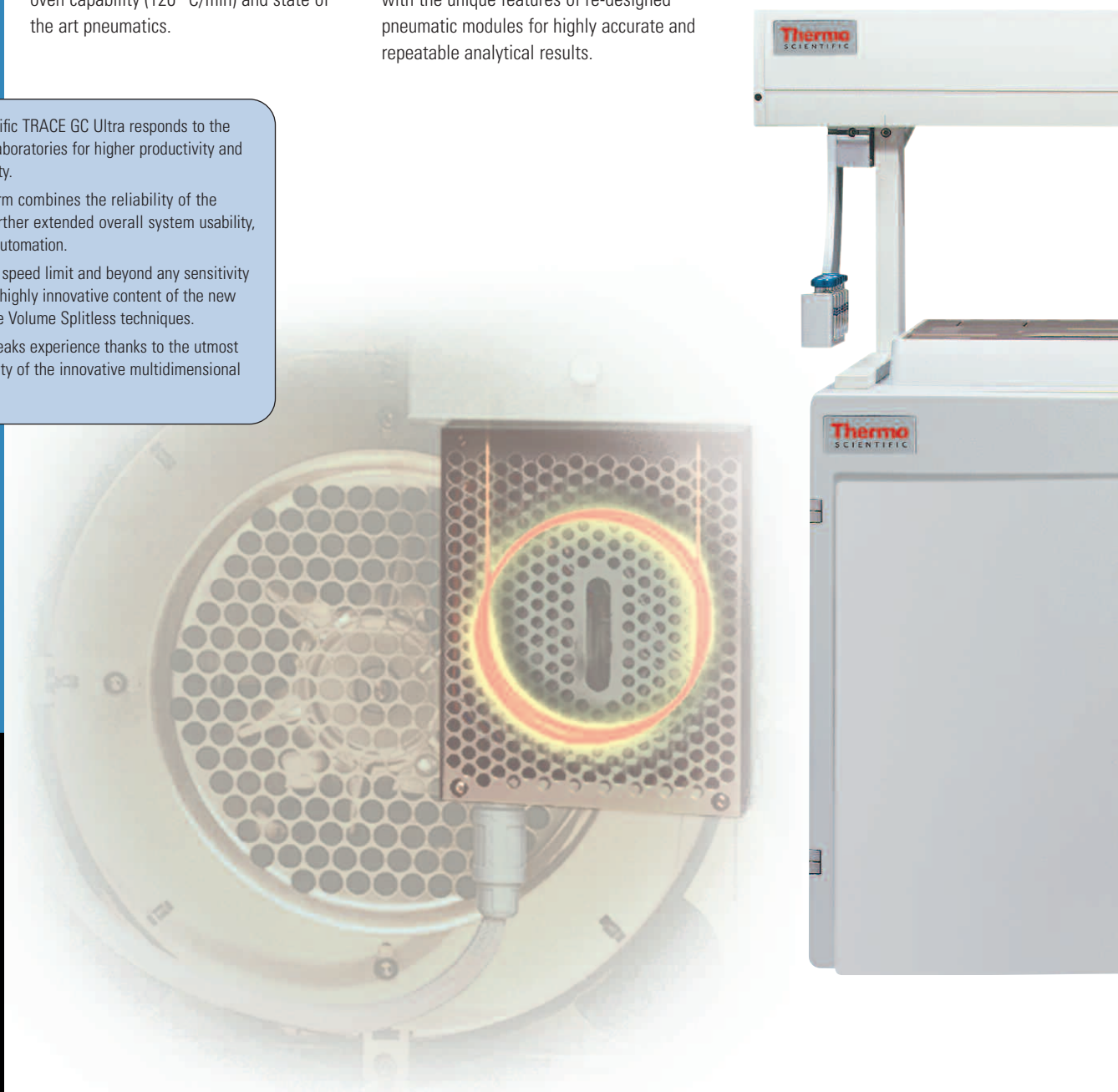



Ultra in Sensitivity

You can inject up to 250 μL with Large Volume On-column injection, and up to 250 μL with Solvent Split PTV (Programmable Temperature Vaporizing). And now, for the very first time, you can also increase the sensitivity of the market's most popular injector, the Split-Splitless Injector (SSL), by more than 50 times – at no additional cost, learning curve or method revalidation.

Take advantage of Large Volume Splitless, our patented, breakthrough injection technique. A wide array of highly sensitive detectors complete the offering. And you can change them in minutes or configure them for simultaneous detection, to get the most out of your analyses.

Ultra in Separation

Extend the separation capability of your Trace GC Ultra with the Comprehensive Two Dimensional Gas Chromatographic approach (GCxGC). Thanks to the proprietary Dual Jet CO_2 Cryogenic Modulator (*) fully integrated in the GC you can experience the most advanced separation technology for most complex sample characterization.

(*) Sold under license from Zoex Corp. for thermal modulation

Ultra in System Automation

TRACE GC Ultra offers both low or high throughput capacity: whichever the technique, is just a matter of choice, in line with your budget requirements.

With Thermo Scientific ChromQuest or Chrom-Card data systems, direct control and acquisition, Local Area Networking (LAN) interfacing or remote control and diagnostics are moved beyond lab walls, offering further improvement in efficiency and sample flow productivity.

Ultra in Quality Assurance

A complete qualification package addresses even the most stringent prerequisite stipulated by highly regulated environments. Both hardware and software performance can be routinely certified.

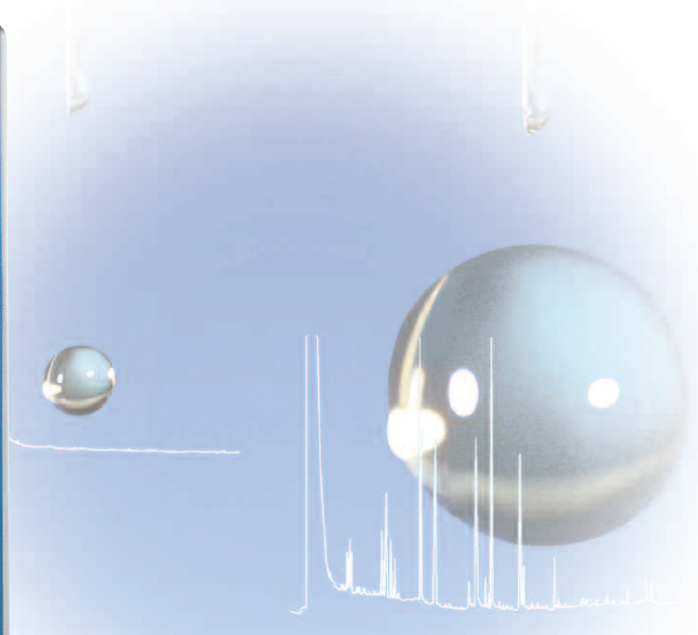

The complete selection of inlets, for the right choice

The best start for good chromatography

Extended Performance Split-Splitless Injector

Optimized for both split and splitless modes of operation to address diluted and concentrated samples respectively, this is a unique injector in its class.

The optimized thermal profile and the unique design demonstrates wide sample linearity, which permits Large Volume Injections of up to 50 μL , while virtually eliminating discrimination.

Contamination and septum bleed effects are prevented by an efficient double sweeping chamber. Additionally, wide bore and packed columns can be easily connected for increased flexibility and added cost savings.

This injector is the ideal solution for samples having limited range of volatility in both dirty or clean matrices.

In addition, this is the only system capable of Large Volume Splitless injections!

Wide or narrow volatility range, clean or dirty matrices, stable or labile compounds: TRACE GC Ultra offers the most appropriate inlet design for each sample.

True Cold On-Column Injector

TRACE GC Ultra offers the only true Cold On-column injector, the reference standard by which all other sampling systems are measured.

Through this inlet, samples are injected directly into the capillary column, avoiding high temperature vaporization processes that may adversely affect quantitative results.

A permanent air cooling of the injector body prevents in-needle vaporization, and a programmable secondary air-cooling system temporarily isolates the needle tip and the injection zone from the oven. This results in total elimination of discrimination and thermal degradation, even allowing injection of very volatile solvents, and prevention of sample back ejection and band broadening effects.

Packed and Purged Packed

Dedicated vaporizing injectors allow TRACE GC Ultra to offer an affordable solution also when using packed (glass and metal) or wide bore capillary columns.

In addition, the HOT (High Oven Temperature) device allows for cold on-column injections to be performed even at high initial oven temperatures.

By precisely controlling the temperature at injection point, medium and high boiling compounds can be analyzed isothermally or by short temperature programs, dramatically shortening overall cycle times.

Sample volume up to 250 μL in a single shot can be easily introduced using the Large Volume On-column option.

This reduces sample preparation and delivers increased sensitivity at lower cost per analysis.

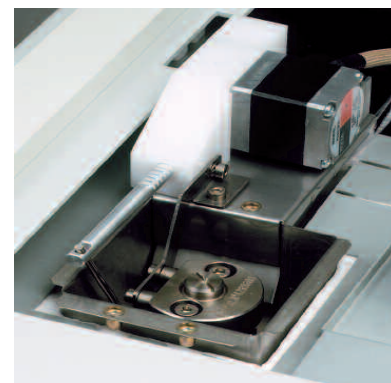
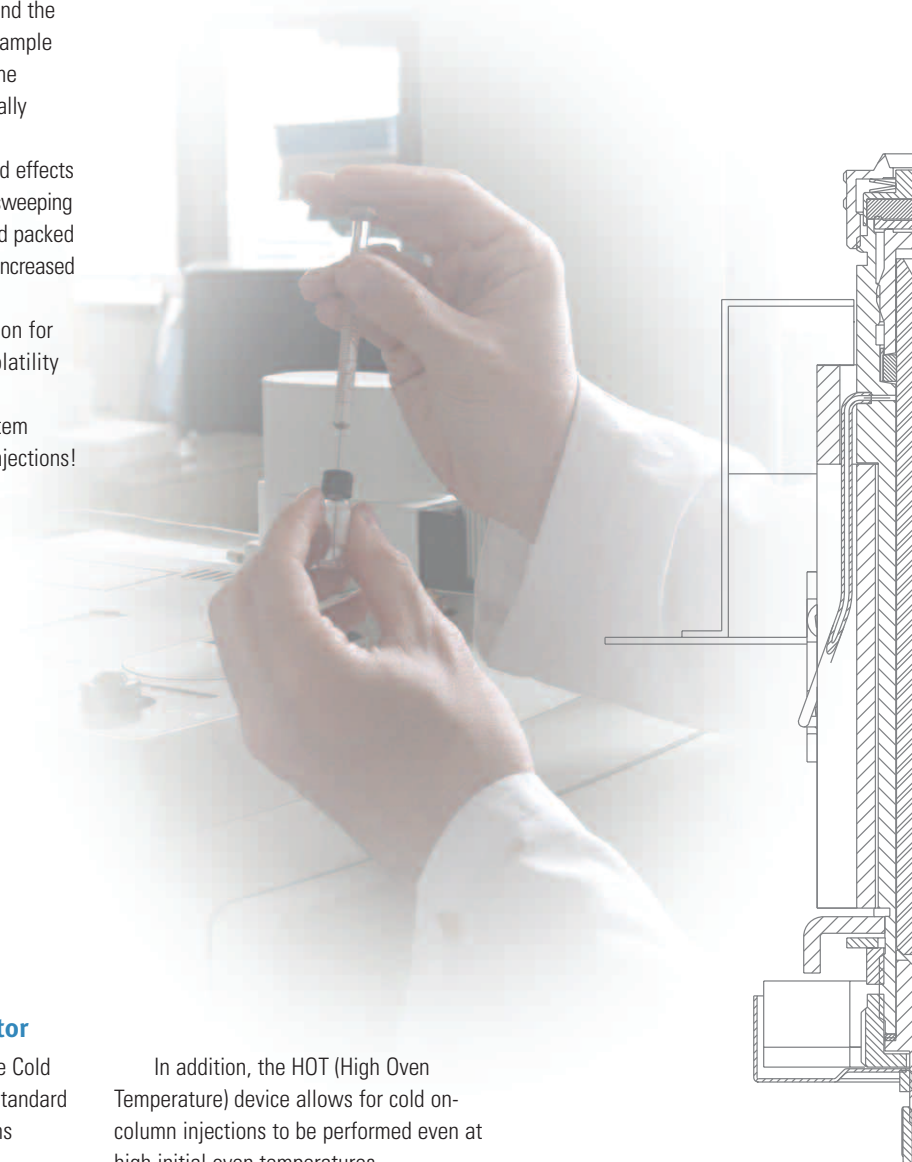

BEST PTV™ (Brightly Enhanced Sample Transfer PTV Injector)

By combining inert liners and a long vaporizing chamber with reduced internal diameter, the BEST PTV is able to completely preserve sample integrity in virtually all situations.

Moreover, its low thermal mass allows it to achieve one of the fastest heating rates (up to 15 °C/s) on the market, thus ensuring complete sample transfer to the analytical column also for high-boiling compounds.

Its programmability with up to 5 different operation modes covers all the various vaporizing injection techniques.

Smart design of the cooling system permits rapid cool down with just ambient air forced by a built-in fan. The cryogenic options available (LN₂ and LCO₂) are used only when initial sub-ambient temperatures are required.

Volumes as large as 250 µL can be automatically injected through the Large Volume PTV option, making trace analyses of polluted samples carried out with no additional costs, at the highest level of accuracy.

This proprietary injector is the perfect solution for the analysis of undilutable and dirty samples as well as medium-boiling-point compounds: the ideal complement to the Cold On-column injection.

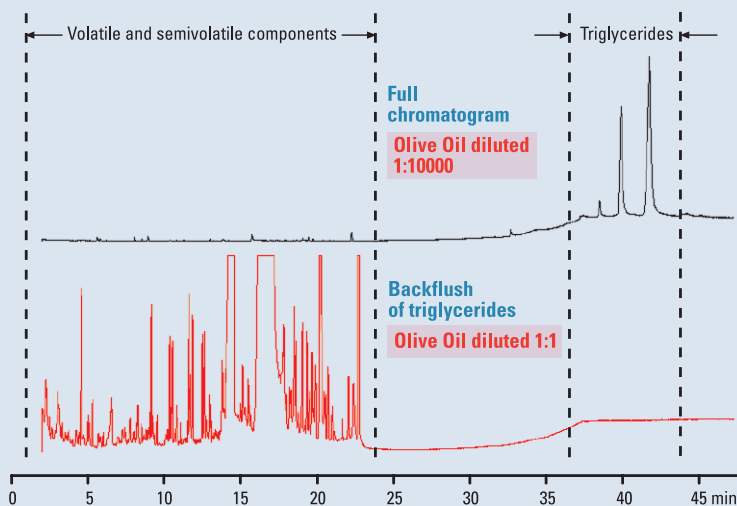
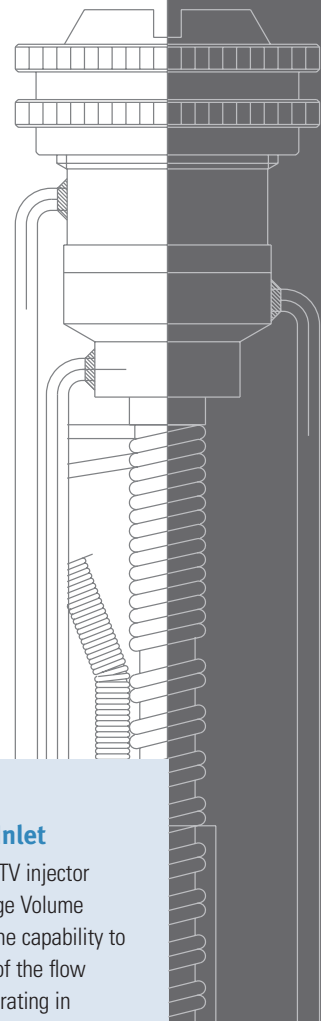
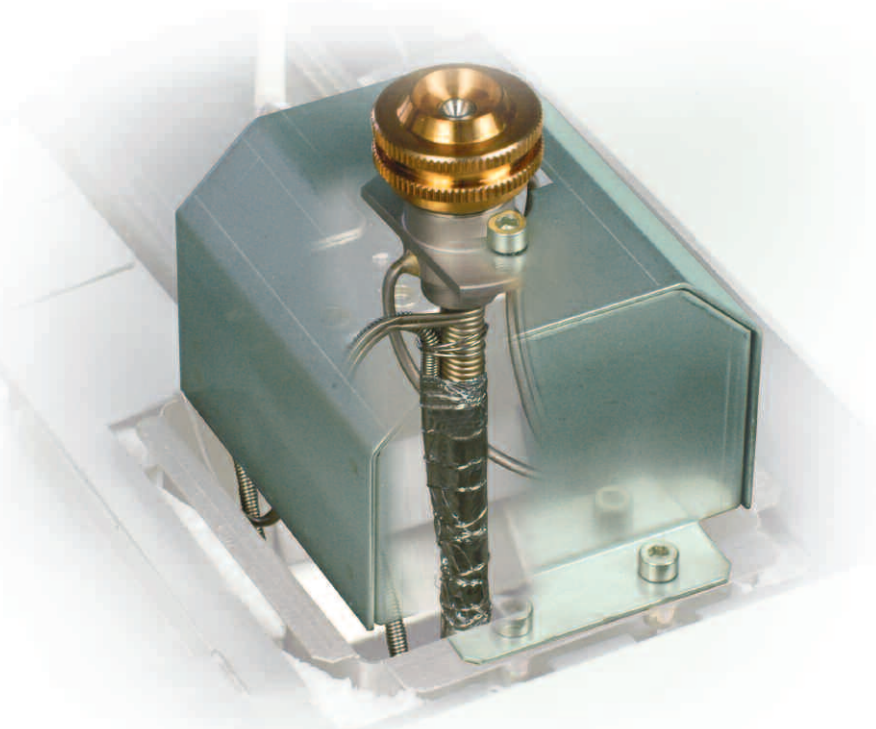

Backflush Kit for PTV Inlet

Designed to expand overall PTV injector performance, even in the Large Volume mode, this accessory offers the capability to shortly reverse the direction of the flow inside the injector. When operating in “reverse flow mode”, heavy or “undesired” compounds can be vented from the split line without eluting into the analytic column, while still maintaining a carrier gas flow through the analytical column.

Another extremely powerful tool to:

1. Dramatically reduce analysis time
2. Enhance PTVLVI performance
3. Provide impressive ease of injector’s maintenance even with MS
4. Prevent column degradation
5. Improve chromatographic resolution

Immediate and easy detector inter-changeability is the Ultra value

A prompt response to your sample's concentration

Multiple Response in a Single GC Run

The possibility to simultaneously combine different detection characteristics can largely extend the amount of data delivered in a single GC run. In-series, stacked or parallel configurations of detectors featuring different selectivity and sensitivity allow you to obtain two or even three different chromatograms (up to three detectors may be operated simultaneously) from the same analysis.



In line with your lab's evolution, TRACE GC Ultra combines utmost sensitivity with added versatility, highly increasing the information/analysis ratio.

Available detectors

- Thermal Conductivity Detector (TCD)
- Flame Ionization Detector (FID)
- Electron Capture Detector (ECD)
- Nitrogen Phosphorus Detector (NPD)
- Flame Photometric Detector (FPD)
- Photoionization Detector (PID)
- Pulsed Discharge Helium Ionization Detector (PDD)
- Entire Thermo Scientific MS range

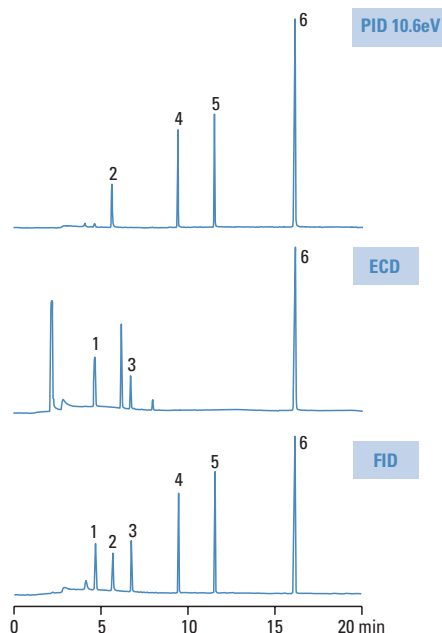

Headspace analysis of organic volatiles in water

Sample: waste water
 Incubation: 30 min at 70°C with shaker
 Injection volume: 2 ml
 Carrier gas: He 2 ml/min
 Oven temp.: 50°C (1 min) at 10°C/min
 up to 150°C (5 min)
 Detectors: PID, FID, ECD in series
 Column: PS255, 30 m x 0.32 mm i.d.,
 2 µm f.t.
 Split ratio: 1/10

- 1 Dichloromethane
- 2 Methyl ethyl ketone
- 3 Dichloroethane
- 4 Toluene
- 5 m-Xylene
- 6 o-Dichlorobenzene

Flame Photometric Detector (FPD)

The unique combustion chamber provides a signal-to-noise ratio for phosphorus compounds ten times greater than traditional FPD detectors. A second photomultiplier can be implemented easily for simultaneous determination of phosphorus and sulfur (or tin) compounds.



Pulsed Discharge Helium Ionization Detector (PDD)

Featuring a non-radioactive source, it is the right replacement for the traditional Helium ionization detector, not being subjected to radioactive material regulations. PDD is the ideal universal detector for attaining sensitivity in the low ppb range. Its electronics have been proprietary optimized to have "zero parameter set-up" (only on/off button) for extreme ease of use.



Electron Capture Detector (ECD)

With the micro cell volume design, detection limits in the parts per trillion range and linear dynamic range of four orders of magnitude

can routinely be achieved. Important

savings in time and service costs are the benefits of its unique structural concept: the collector electrode geometry allows easy access for cleaning without reaching the source, making this operation possible by any technician. Safety wipe tests are required only every three years, further decreasing maintenance costs.

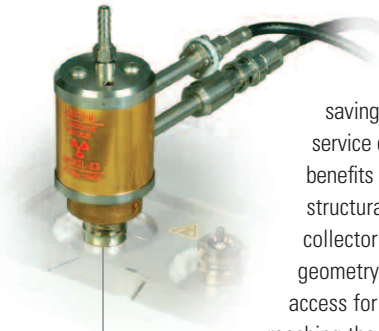

Photoionization Detector (PID)

The unique capability to operate at temperatures up to 400 °C extends detection to high boiling compounds. The patented lamp-cooling design and the highly inert sample pathway increase lamp lifetime for low cost of ownership and permit analysis of thermally labile compounds.



Universal Base Body Approach

The presence of a base body common to all GC ionization detectors makes switching from one detector to another possible using common, every-day tools by lab personnel (no service call is necessary). You can be ready to run samples in only a few minutes, just like having more GCs in place of one. Urgent analysis completed – problem solved.

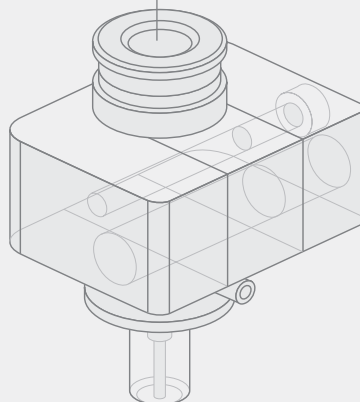

Full spectrum of sampling systems for all needs

Unattended around-the-clock operation

Series 3000 Liquid Sampling Systems

Establishing the Performance/Simplicity=1 paradigm makes simplicity directly proportional to top performance. The Thermo Scientific 3000 Series is the ideal solution for conventional routine analysis in vaporizing injectors.

Engineered to meet the highest level of ruggedness and ease of use, this product can perfectly fulfill the requirements of both QA/QC or high throughput environments.

The AI 3000 Autoinjector is an 8-position sampling module. It combines the high precision of an automatic injection system with the ease of use of the Plug & Play concept, and represents the ideal answer to those labs requiring highly reliable results even for small batches of samples.

A special upgrade option allows you to turn the AI 3000 into the high throughput AS 3000 Autosampler with the addition of a 105 sample tray, making the initial investment a worthwhile choice.

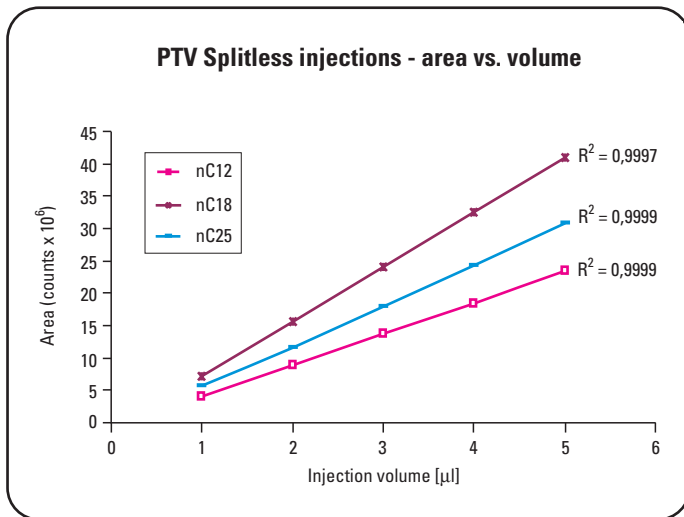

A wide range of modular, automated sample preparation injection systems helps reduce cost per analysis and increase productivity levels.

“Tool Free” Upgradability

Choose your investment and get the most out of it.

Following the growing business of your lab, expansion from the 8-position sample tray to a 105 sample capacity system is accomplished in a jiffy, adding the rotating carousel with integrated electronics.

Both AI/AS 3000 can be installed either on the right or on the left hand side of the TRACE GC Ultra just by swapping the sample container or sample tray's side; the automatic recognition of the position will do the rest.



TriPlus AS, HS and SPME* Autosampler

Conceived around a triple axis (X-Y-Z) model, the Thermo Scientific TriPlus Autosampler provides the highest flexibility together with extreme ease of use, thanks to unbeatable features:

- Quick installation and easy start-up through self alignment procedure
- Self recognition of installed accessories
- Snap-on interchangeable turrets for Liquid and Headspace sampling
- Simultaneous operations on two GCs by the same sampling unit, managed through two independent methods
- Full automation of entire SPME analytical cycle

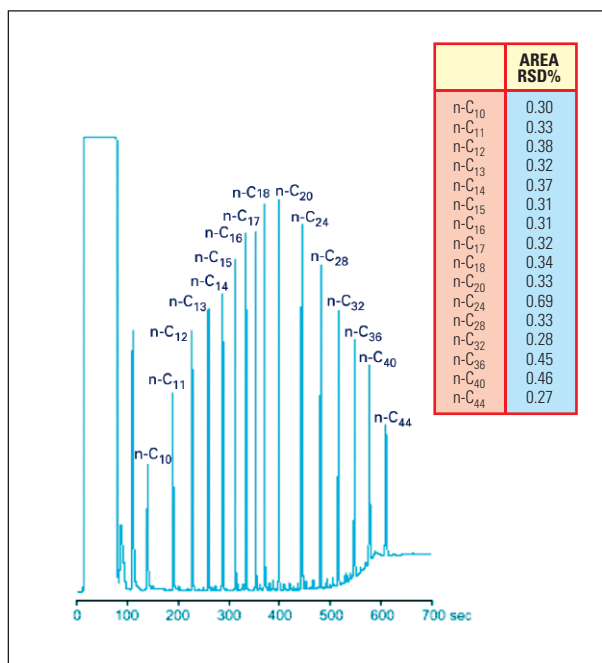

Typical repeatability of 1 µL injection of 4 ppm C10-C44 solution in hexane (10 repetitions)

Headspace Sampling

With no use of transfer lines for gas sampling, the TriPlus HS is able to combine superior accuracy and rapidity with unrivalled simplicity of operation. The heated proprietary gastight syringe is able to ensure complete sample transfer avoiding any condensation, while the 6-position heated incubation oven with shaker significantly speeds-up the sample preparation step.

Straightforward selection of sampling volumes and zero bench space requirements are added to unprecedented sample throughput capabilities (up to 108 sample vials).



* Sold under license from Supelco®



Liquid Sampling

Compatible with Thermo Scientific GC inlets, the TriPlus™ AS is the solution for “advanced” injection techniques. By offering the highest flexibility in parameter selection, it allows injection procedures such as Large Sample Volume, solvent flush, or internal standard addition to be accomplished in the most efficient way and with the maximum degree of accuracy. Up to 300 vials can be housed on the same unit.

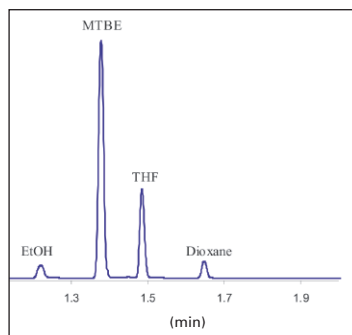

10 ppm of each component in water.
2 mL sample in a 20 mL vial.

Repeatability of Headspace analysis of solvents in water (7 runs).

Oven	70 °C (incubation time 50 min, agitation 30 sec on, 30 sec off)
Syringe	120 °C, 1 mL headspace injected

	ETHOH	MTBE	THF	DIOXANE
	585805	8293631	2919184	538229
	576243	8261296	2939842	527843
	580386	8026631	2889706	530884
	573839	8025647	2867534	525765
	573065	8179238	2904440	525183
	572173	8253048	2879742	524895
	584948	8033903	2916050	536534
Average	578065	8153342	2902357	529905
SD	5680	121501	25047	5522
RSD%	0.98	1.49	0.86	1.04

Research caliber results through high precision digital gas controls

Low and high pressure (250 and 1000 kPa) re-designed digital pneumatic modules provide for utmost reliability and represent the optimal solution for all analytical needs. While the former is ideal for high precision and accuracy in carrier gas control with standard and widebore capillary columns, the latter ensures utmost performance with narrowbore capillary columns in fast and ultra fast GC applications.

Furthermore, the standard gas saver function provides the ability to reduce the split flow during the analytical cycle, eliminating the waste of carrier gas.

In addition, TRACE GC Ultra offers proprietary Algorithm for Column Characterization (ACC), and Leak Check functions right at your fingertips.

A wide range of solutions minimizes up-front investment and lowers cost of ownership:

- A high precision and ultrastable column oven capable of rapid heat-up and cool-down rates allows conventional fast GC with narrow bore capillary columns.
- State of the art digital pneumatics grant utmost retention time reproducibility.
- A series of smart accessories further expands the efficiency of your GC platform:
 - Valve Oven for Petrochemical Turn-key Analyzers
 - Cold Trap
 - Oven Cryo
 - TD & P&T Interface Kit
 - Merlin Microseal™ Septumless Device
 - Methanizer for FID



Assisted Leak Check

This built-in diagnostic tool is your ideal assistant to routinely check your GC system. Automated steps will guide your operations required for both instrument control and injector maintenance.

Exclusive Tool for Instrument Accuracy and Repeatability

ACC delivers unrivalled "column-to-column" and "instrument-to-instrument" retention time repeatability! This unique feature permits you to evaluate and store the real column parameters reflecting the actual column pneumatic resistance with much higher accuracy.

Automatic calculation of the void time allows to easily compensate RT deviations caused by column trimming. Besides, GC-to-GC or GC/MS method transfer can be accomplished in a rapid and straightforward manner.

The best Data System answers to every laboratory size

Instrument control, data acquisition and handling that fit the way you work

Thermo Scientific Chrom-Card 32-Bit

This 32-bit software benefits from the extensive gas chromatography knowledge typically available in the analytical laboratory, and is a cost-effective software solution for rapid instrument control and data acquisition and handling. Shaped around the TRACE GC Ultra and the concept of simplicity Chrom-Card™, is the right choice for GC specific laboratories. Redundancies that unnecessarily complicate data handling systems are eliminated, bringing the user up to a high productive level in a very short time.

Local Area Networking (LAN) interfacing for remote control and wide Data System connectivity are the power of automation of the TRACE GC Ultra.

Thermo Scientific ChromQuest

ChromQuest™ is a multi-technique chromatography software platform conceived to maximize productivity.

Targeted to laboratories looking for advanced handling capabilities and high levels of flexibility, it allows any distributed architecture to be easily scalable from a single system to an enterprise-wide network.

Besides standard workstation configuration, ChromQuest is configurable for Client/Server environment: any instrument configured as part of the enterprise can be monitored and controlled by any authenticated client.

Operating under the major software platforms (as Microsoft® Windows® 2000 and XP), these software packages allow compliance with all the requirements of the most modern laboratories in terms of data security, reporting and networking. Password protection and profile-selective accessibility, GLP, 21 CFR Part 11, and internal validation procedures are the new standards: Chrom-Card and ChromQuest are the solution.



Complete System Qualification

The available qualification package allows you to sign, date, and execute the instrument's compliance to the required standards in a timely manner throughout the life of your TRACE GC Ultra. A further assurance for organizations having regulatory agencies auditing their analytical instruments, offering the right solution for highly regulated environments:

Installation Qualification (IQ):

Guarantees correct instrument acceptance and proper installation

Operational Qualification (OQ):

Ensures that instrument will function according to its operational specification in the selected environment and proves the instrument's consistent performance over time, according to a specification appropriate for its routine use.

Thermo Scientific Columns and Consumables



Thermo Scientific TRACE GC columns, syringes and consumables, including injection port liners, ferrules, gas filters, and septa, are designed to complement our innovative range of GC and GC/MS systems. This wide range of consumables and accessories is designed to offer application-focused solutions to customers in the petrochemical, food & beverage and environmental industries.

- Wide range of low bleed, high temperature columns
- Consumables tested and certified on Thermo Scientific instruments
- Gas filters to improve column lifetimes and system stability
- Vials guaranteed for the Thermo Scientific autosampler systems

Laboratory Solutions Backed by Worldwide Service and Support

Tap our expertise throughout the life of your instrument. Thermo Scientific Services extends its support throughout our worldwide network of highly trained and certified engineers who are experts in laboratory technologies and applications. Put our team of experts to work for you in a range of disciplines, from system installation, training and technical support, to complete asset management and regulatory compliance consulting. Improve your productivity and lower the cost of instrument ownership through our product support services. Maximize uptime while eliminating the uncontrollable cost of unplanned maintenance and repairs. When it's time to enhance your systems, we also offer certified parts and a range of accessories and consumables suited to your application.

To learn more about our products and comprehensive service offerings, visit our Web site at www.thermo.com.

In addition to these offices, Thermo Fisher Scientific maintains a network of representative organizations throughout the world.

Africa-Other

+27 11 570 1840 • analyze.sa@thermo.com

Australia

+61 2 8844 9500 • analyze.au@thermo.com

Austria

+43 1 333 50 34 0 • analyze.at@thermo.com

Belgium

+32 2 482 30 30 • analyze.be@thermo.com

Canada

+1 800 530 8447 • analyze.ca@thermo.com

China

+86 10 8419 3588 • analyze.cn@thermo.com

Denmark

+45 70 23 62 60 • analyze.dk@thermo.com

Europe - Other

+43 1 333 50 34 0 • analyze.emea@thermo.com

Finland/Norway/Sweden

+46 8 556 468 00 • analyze.se@thermo.com

France

+33 1 60 92 48 00 • analyze.fr@thermo.com

Germany

+49 6103 408 1014 • analyze.de@thermo.com

India

+91 22 6742 9434 • analyze.in@thermo.com

Italy

+39 02 950 591 • analyze.it@thermo.com

Japan

+81 45 453 9100 • analyze.jp@thermo.com

Latin America

+1 608 276 5659 • analyze.la@thermo.com

Middle East

+43 1 333 50 34 0 • analyze.emea@thermo.com

Netherlands

+31 76 579 55 55 • analyze.nl@thermo.com

South Africa

+27 11 570 1840 • analyze.sa@thermo.com

Spain

+34 914 845 965 • analyze.es@thermo.com

Switzerland

+41 21 694 71 11 • analyze.ch@thermo.com

UK

+44 1442 233555 • analyze.uk@thermo.com

USA

+1 800 532 4752 • analyze.us@thermo.com

www.thermo.com

ISO 9001

DNV-CERT-00203-FI-RO

Thermo Fisher Scientific S.p.A, Milan, Italy is ISO Certified.

©2009 Thermo Fisher Scientific Inc. All rights reserved. Microseal is a trademark of the Merlin Instrument Company. Microsoft and Windows are registered trademarks of Microsoft Corporation. Supelco is a registered trademark of Sigma-Aldrich Inc. All other trademarks are the property of Thermo Fisher Scientific Inc. and its subsidiaries.

Specifications, terms and pricing are subject to change. Not all products are available in all countries. Please consult your local sales representative for details.

BR10125_E 11/09C

Thermo
SCIENTIFIC